

























**Elektriciteit**

-  Enkelpolige schakelaar
-  Dubbelpolige schakelaar
-  Dubbele richting schakelaar
-  Enkel stopcontact
-  Elektrische aansluiting
-  Thermostaat
-  bewegings sensor
-  Lichtpunt
-  Wandlichtpunt
-  Tv distributie
-  Telefoonaansluiting
-  UTP-aansluiting
-  Elektrisch bord
-  Wasmachine
-  Droogkast
-  CV-ketel
-  enkel trekdraad
-  LS
-  CLS
-  rookmelder
-  Videofoon
-  Radiator

**Technische wanddeling berging**

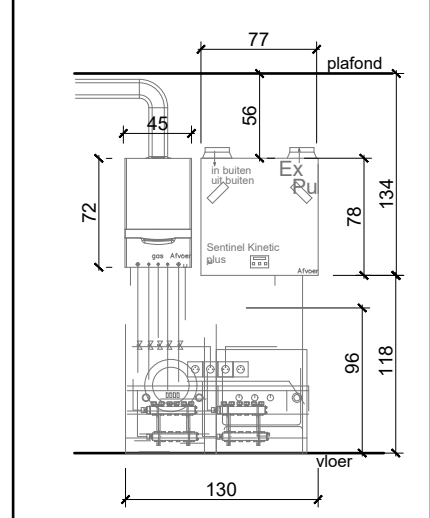

Indeling + technieken volgens leidschema leverancier keuken

**NOTA**  
 Deze tekening vervangt alle voorgaande tekeningen  
 Vals plafond  
 Inplanting keuken en sanitaire toestellen zie detailplan leverancier + positionering van het bijhorende leidingnet.  
 Alle stopcontacten op hoogte 0,30m tov. pas 0.00  
 Alle schakelaars op hoogte 1,10m tov. pas 0.00  
 Thermostaat + videofoon op hoogte 1,65m tov. pas 0.00



Tweemontstraat 258  
 2100 Antwerpen  
 Telefoon 03/727.28.29

**Residentie De Stroppen**

KLANT:

Schaal: 1/50  
 Appartement  
 1.06

Datum: 03/05/2019  
 wijz.: