

Inplantingsplan 1/500

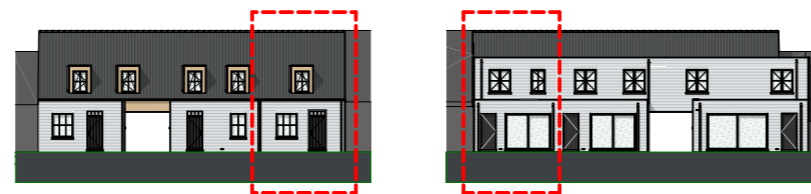

Gevels woning 1/500

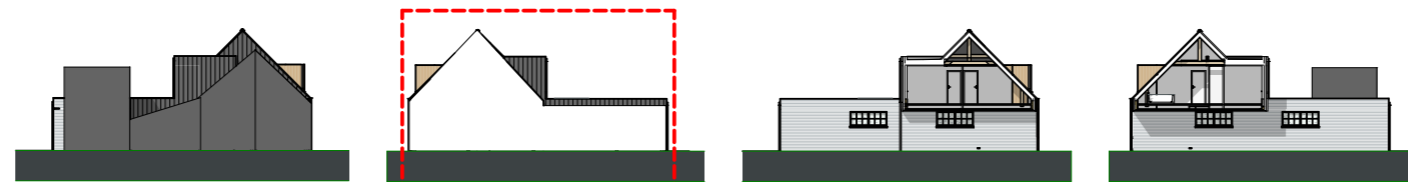

Gevels woning 1/500



Gevels carport/berging 1/500

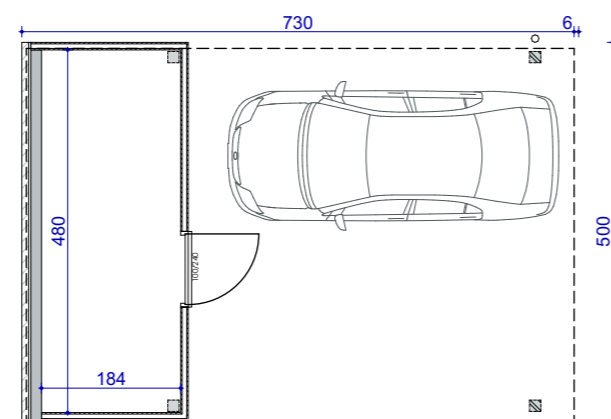

Carport/berging 1/100

Alle aanduidingen op dit plan zijn indicatief en worden bepaald in functie van de studie en de keuze, de toepassing en uitvoering van de materialen



KVT IMMO



Woning 03  
 Heikant 22 - Bevel (Nijlen)

woning rechts  
 2 slaapkamers

Oppervlakte  
 Woning  
 ± 143,35 m<sup>2</sup>

Oppervlakte  
 Weide  
 ±317,10m<sup>2</sup>

Oppervlakte  
 Tuin (+terras)  
 ± 76,30 m<sup>2</sup>

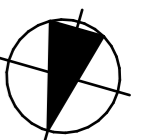
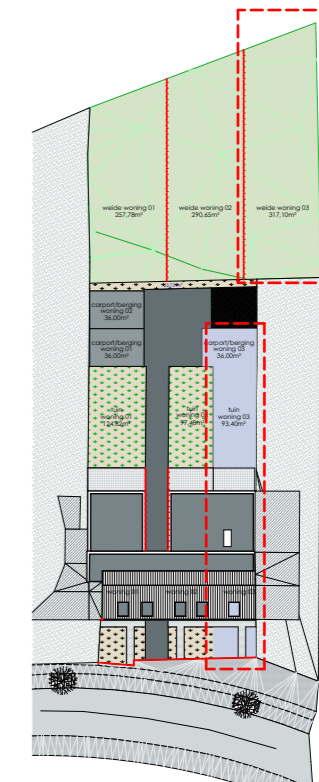

Oppervlakte  
 Perceel  
 ± 252,96m<sup>2</sup>